

# VEO-XPS43

HDMI EXTENDERS

*4K Single Cat.6 Extender Kit*



## USER MANUAL

# INDEX

<b>1. IMPORTANT REMARK.....</b>	<b>3</b>
<b>2. IMPORTANT SAFETY INSTRUCTIONS.....</b>	<b>3</b>
<b>3. IMPORTANT NOTE.....</b>	<b>5</b>
<b>4. INTRODUCTION.....</b>	<b>5</b>
<i>4.1. Main Features.....</i>	<i>5</i>
<b>5. PACKAGES CONTENT.....</b>	<b>6</b>
<b>6. PANELS DESCRIPTION.....</b>	<b>6</b>
<i>6.1. Transmitter Front and Rear Panel.....</i>	<i>6</i>
<i>6.2. Receiver Front and Rear Panel.....</i>	<i>7</i>
<b>7. DEVICE CONNECTIONS.....</b>	<b>8</b>
<b>8. MECHANICAL DIAGRAM.....</b>	<b>9</b>
<i>8.1. Transmitter.....</i>	<i>9</i>
<i>8.2. Receiver.....</i>	<i>9</i>
<b>9. TECHNICAL SPECIFICATIONS.....</b>	<b>10</b>

## 1. IMPORTANT REMARK



WARNING: SHOCK HAZARD - DO NOT OPEN  
AVIS: RISQUE DE CHOC ÉLECTRIQUE - NE PAS OUVRIR



The lightning flash with arrowhead symbol, within an equilateral triangle, is intended to alert the user to the presence of uninsulated “dangerous voltage” within the product’s enclosure that may be of sufficient magnitude to constitute a risk of electric shock to persons.



The exclamation point within an equilateral triangle is intended to alert the user to the presence of important operating and maintenance (servicing) instructions in the literature accompanying the appliance.

**WARNING (If applicable):** The terminals marked with symbol of “” may be of sufficient magnitude to constitute a risk of electric shock. The external wiring connected to the terminals requires installation by an instructed person or the use of ready-made leads or cords.

**WARNING:** To prevent fire or shock hazard, do not expose this equipment to rain or moisture.

**WARNING:** An apparatus with Class I construction shall be connected to a mains socket-outlet with a protective earthing connection.

## 2. IMPORTANT SAFETY INSTRUCTIONS

1. Read these instructions.
2. Keep these instructions.
3. Heed all warnings.
4. Follow all instructions.
5. Do not use this apparatus near water.
6. Clean only with dry cloth.
7. Do not block any ventilation openings. Install in accordance with the manufacturer’s instructions.
8. Do not install near any heat sources such as radiators, heat registers, stoves, or other apparatus (including amplifiers) that produce heat.

9. Do not defeat the safety purpose of the polarized or grounding type plug. A polarized plug has two blades with one wider than the other. A grounding type plug has two blades and a third grounding prong. The wide blade or the third prong are provided for your safety. If the provided plug does not fit into your outlet, consult an electrician for replacement of the obsolete outlet.
10. Protect the power cord from being walked on or pinched particularly at the plugs, convenience receptacles, and at the point where they exit from the apparatus.
11. Only use attachments/accessories specified by the manufacturer.
12. Unplug the apparatus during lightning sorts or when unused for long periods of time.
13. Refer all servicing to qualified personnel. Servicing is required when the apparatus has been damaged in any way, such as power supply cord or plug is damaged, liquid has been spilled or objects have fallen into the apparatus, the apparatus has been exposed to rain or moisture, does not operate normally, or has been dropped.
14. Disconnecting from mains: When switching off the POWER switch, all the functions and light indicators of the unit will be stopped, but fully disconnecting the device from mains is done by unplugging the power cable from the mains input socket. For this reason, it always shall remain easily accessible.
15. Equipment is connected to a socket-outlet with earthing connection by means of a power cord.
16. The marking information is located at the bottom of apparatus.
17. The apparatus shall not be exposed to dripping or splashing and that no objects filled with liquids, such as vases, shall be placed on apparatus.

**NOTE:** *This equipment has been tested and found to comply with the limits for a Class A digital device, pursuant to part 15 of the FCC Rules. These limits are designed to provide reasonable protection against harmful interference when the equipment is operated in a commercial environment. This equipment generates, uses, and can radiate radio frequency energy and, if not installed and used in accordance with the instruction manual, may cause harmful interference to radio communications. Operation of this equipment in a residential area is likely to cause harmful interference in which case the user will be required to correct the interference at his own expense.*



**WARNING:** This product must not be discarded, under any circumstance, as unsorted urban waste. Take to the nearest electrical and electronic waste treatment centre.

**NEEC AUDIO BARCELONA, S.L.** accepts no liability for any damage that may be caused to people, animal or objects due to failure to comply with the warnings above.

### 3. IMPORTANT NOTE

Thank you for choosing our Ecler **VEO-XPS43 4K Single Cat.6 Extender Kit!**

It is **VERY IMPORTANT** to carefully read this manual and to fully understand its contents before any connection in order to maximize your use and get the best performance from this equipment.

To ensure optimal operation of this device, we strongly recommend that its maintenance be carried out by our authorised Technical Services.

**All ECLER products are covered by warranty**, please refer to [www.ecler.com](http://www.ecler.com) or the warranty card included with this product for the period of validity and conditions.

### 4. INTRODUCTION

The Ecler VEO-XPS43 is a professional HDMI extender kit that allows to extend Ultra High Definition Audio and Video signals over a single Cat. 6 cable up to 30m of distance and FullHD signals up to 60m with zero-latency. VEO-XPS43 includes EDID management features and it supports IR pass through, for seamless integration. VEO-XPS43 is a simple and cost effective solution for all the professional applications where an Ultra High Definition HDMI extension is required.

#### 4.1. Main Features

- Complete HDMI Extender Kit for HDMI Audio Video and IR signals extension over single Cat.6 cable
- Supports up to 4K/30Hz Ultra High Definition resolution.
- Compact design for easy and flexible installation
- Supports EDID copying from receiver display or loop out display.
- Allows for cascading via additional HDMI loop out port.
- Support Power over cable function (Receiver is powered by Transmitter)
- Works with HDMI and HDCP compliant devices.

## 5. PACKAGES CONTENT

- 1 x Transmitter Unit
- 1 x Receiver Unit
- 1 x 12VDC 1A International Power Supply (One PSU for both units)
- 1 x IR Blaster unit
- 1 x IR Receiver unit

## 6. PANELS DESCRIPTION

### 6.1. Transmitter Front and Rear Panel

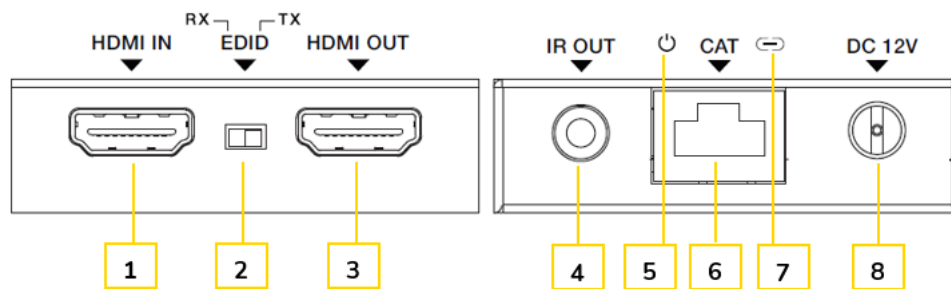

- 1. HDMI IN connector:** Connect this input to the HDMI source.
- 2. EDID SWITCH:** The switch is used for selecting EDID. In the right position, the extender will copy the HDMI loop out display EDID information to the source; In the left position the extender will copy the receiver display EDID to the source.
- 3. HDMI OUT CONNECTOR:** Connect this output to a local display or use it for daisy chaining another VEO-XPS43 transmitter.
- 4. IR OUT CONNECTOR:** Connect it to the included IR Blaster for extending an IR signal from the display to the source.

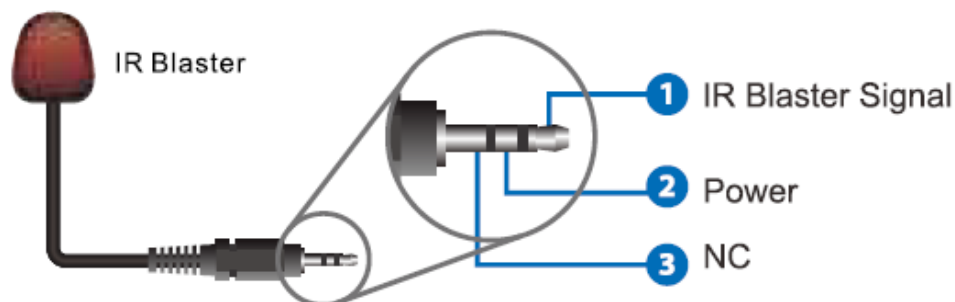

- 5. POWER LED:** This LED will be lit when the transmitter is power supplied.

6. **CAT CONNECTOR:** Connect it to the receiver input port using a CAT. 6 cable. Only point-to-point connections are allowed.
7. **CONNECTION LED:** This LED indicates the state of the HDMI connection:
  - Light on: HDMI signal with HDCP.
  - Light flashing: HDMI signal without HDCP.
  - Light off: No HDMI signal audio output.
8. **DC 12V port:** Connect this port to the 12Vdc included power supply.

## 6.2. Receiver Front and Rear Panel

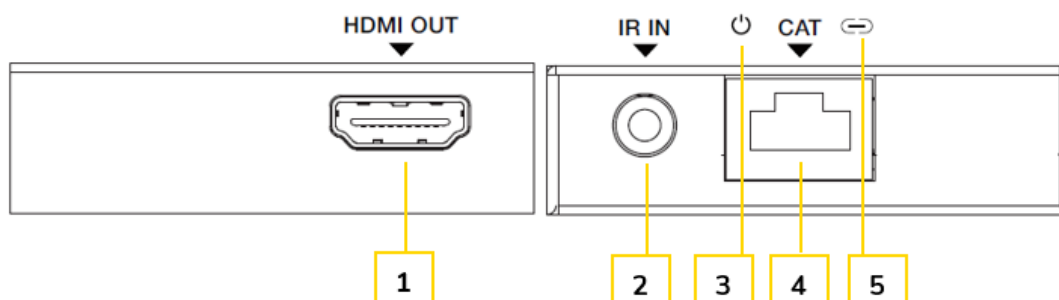

1. **HDMI OUT CONNECTOR:** Connect this output to the HDMI display.
2. **IR IN CONNECTOR:** Connect it to the included IR Receiver for extending an IR signal from the display to the source.

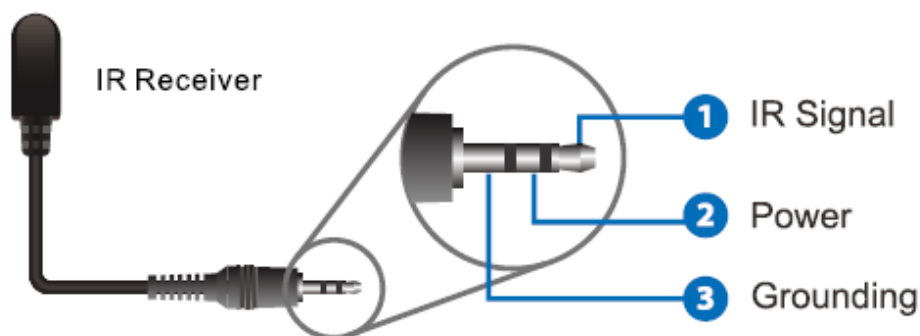

3. **POWER LED:** This LED will be lit when the receiver is power supplied.
4. **CAT CONNECTOR:** Connect it to the transmitter input port using a CAT. 6 cable. Only point to point connections are allowed.
5. **CONNECTION LED:** This LED indicates the state of the HDMI connection:
  - Light on: HDMI signal with HDCP.
  - Light flashing: HDMI signal without HDCP.
  - Light off: No HDMI signal audio output.

## 7. DEVICE CONNECTIONS

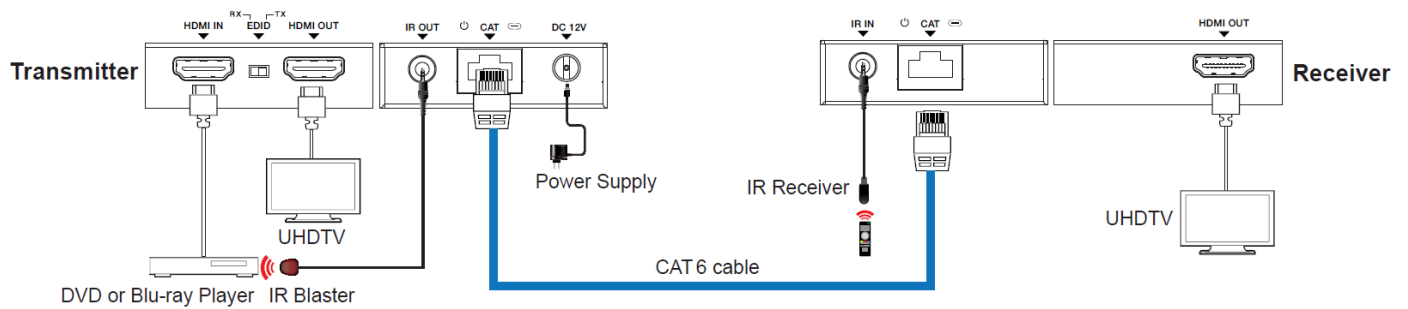

Good quality standard Ethernet Cat. 6 cables (or superior) are required to connect transmitter and receiver in order to avoid connection issues and malfunctioning. Shielded cables and shielded connectors are mandatory to ensure a good ground signal reference to the receiver and avoid electromagnetic interferences along the cable.



## 8. MECHANICAL DIAGRAM

### 8.1. Transmitter



### 8.2. Receiver



## 9. TECHNICAL SPECIFICATIONS

### VEO-XPS43

Video Performances	
Supported Resolutions	Up to 4Kx2K@30Hz
Colorspace	RGB, YCbCr
Chroma Subsampling	4:4:4, 4:2:2
Color Depth	8-bit, 10-bit, 12-bit
Signal Bandwidth	10.2Gbps
HDCP	1.4 compliant
Video Connectors	Transmitter: Type-A Female HDMI Receiver: Type-A Female HDMI
Audio Performances	
Audio Formats	Dolby TrueHD, Dolby Digital, DTS-HD Master Audio, DTS 5.1, PCM;
Sample Rate	32 KHz, 44.1 KHz, 48 KHz, 88.2 KHz, 96 KHz, 176.4 KHz, 192 KHz
PCM bit rate	up to 24-bit
Frequency Response	20Hz–20KHz, ±3dB
Control	
Control Ports	EDID                      Selector Switch
IR	Pass-through            3.5mm Minijack connector
General	
HDMI Distance	up to 10 meters / 33 ft with Ecler VEO cables
Cat.6 Distance	CAT6a/7 @4K            up to 30m / up to 98ft CAT6a/7 @1080p up to 60m / up to 197ft
Environmental	
Operation Temperature	0 to +40°C (32 to +104 °F)
Humidity	20 - 90% RH (no condensation)
Power Supply	
Mains voltage	AC 100V ~ 240V 50/60Hz Output: DC 12V---1A
Rated power consumption	Transmitter: 1.86W, Receiver: 0.87W
Mechanical	
Dimensions	79.5mm x 69mm x 16.5mm (3.13"x2.71"x0.65")
Weight	TX: 132g / 0.291lbs, RX: 130g / 0.286 lbs

All product characteristics are subject to variation due to production tolerances. **NEEC AUDIO BARCELONA S.L.** reserves the right to make changes or improvements in the design or manufacturing that may affect these product specifications.

For technical queries contact your supplier, distributor or complete the contact form on our website, in [Support / Technical requests](#).

Motors, 166-168 08038 Barcelona - Spain - (+34) 932238403 | [information@ecler.com](mailto:information@ecler.com) | [www.ecler.com](http://www.ecler.com)