



BETA57A

Instrument Microphone

The Shure supercardioid dynamic microphone, BETA57A, user guide.
Version: 3.0 (2023-C)

Table of Contents

BETA57A Instrument Microphone	3	Proximity Effect	5
General Description	3	Specifications	5
Features	3	Accessories	6
Applications	3	Furnished Accessories	7
General Rules for Use	3	Optional Accessories	7
Applications and Placement	3	Replacement Parts	7
Avoiding Pickup of Unwanted Sound Sources	4	Certifications	7

BETA57A

Instrument Microphone

General Description

The Shure BETA 57[®]A is a precision-engineered, dynamic microphone designed for professional live sound reinforcement and studio recording. A tight, supercardioid pattern delivers high gain before feedback, maximum sound isolation, and minimum off-axis tone coloration.

The tailored frequency response of the versatile Beta 57A accentuates the fine details of amplified and acoustic instruments, especially in high sound pressure level(SPL) environments. A proven shock mount system, hardened steel-mesh grille, and superior build quality withstand the rigors of daily sound reinforcement.

Features

- Premier live performance microphone with Shure quality, ruggedness, and reliability
- Uniform supercardioid pick-up pattern for maximum gain before feedback and superior rejection of off-axis sound
- Tailored frequency response specifically shaped for guitars, drums and vocals
- Neodymium magnet for greater sensitivity and higher output
- Advanced pneumatic shock mount system that minimizes transmission of mechanical noise and vibration
- Dent-resistant steel mesh grille and enamel coated die-cast metal construction resist wear and abuse

Applications

General Rules for Use

- Do not cover any part of the microphone grille with your hand, as this will adversely affect microphone performance.
- Aim the microphone toward the desired sound source (such as the talker, singer, or instrument) and away from unwanted sources.
- Place the microphone as close as practical to the desired sound source.
- Work close to the microphone for extra bass response.
- Use only one microphone to pick up a single sound source.
- For better gain before feedback, use fewer microphones.
- Keep the distance between microphones at least three times the distance from each microphone to its source (“three to one rule”).
- Place microphones as far as possible from reflective surfaces.
- Add a windscreen when using the microphone outdoors.
- Avoid excessive handling to minimize pickup of mechanical noise and vibration.

Applications and Placement

The following table lists the most common applications and placement techniques. Keep in mind that microphone technique is largely a matter of personal taste; there is no one “correct” microphone position.

Application	Suggested Microphone Placement	Tone Quality
Guitar & Bass Amplifiers	2.5 cm (1 in.) from speaker, on-axis with center of speaker cone.	Sharp attack; emphasized bass.
	2.5 cm (1 in.) from speaker, at edge of speaker cone.	Sharp attack; higher frequency sound.
	15 to 30 cm (6 to 12 in.) away from speaker and on-axis with speaker cone.	Medium attack; full, balanced sound.
	60 to 90 cm (2 to 3 ft.) back from speaker, on-axis with speaker cone.	Softer attack; reduced bass.
Snare Drum	2.5 to 7.5 cm (1 to 3 in.) above rim of top head of drum. Aim mic at drum head.	Most "snap" from drumstick.
Tom-Toms	One mic on each tom, or between each pair of toms, 2.5 to 7.5 cm (1 to 3 in.) above drum heads. Aim each microphone at top drum heads. On double head toms, you can also remove bottom head and place a mic inside pointing up toward top drum head.	Medium attack; full, balanced sound.
Brass & Woodwinds	Brass: 30 to 90 cm (1 to 3 ft.) away, on-axis with bell of instrument.	Bright, clear sound.
	Woodwinds: 2.5 to 15 cm (1 to 6 in.) away, on-axis with bell of instrument.	Bright, clear sound.
	Bell of instrument 90° off-axis from front of mic.	Softer, mellow sound.

Avoiding Pickup of Unwanted Sound Sources

A supercardioid microphone has the greatest sound rejection at points 120° toward the rear of the microphone. Place the microphone so that unwanted sound sources, such as monitors and loudspeakers, are at these angles, not directly behind it. To minimize feedback and ensure optimum rejection of unwanted sound, always test microphone placement before a performance.

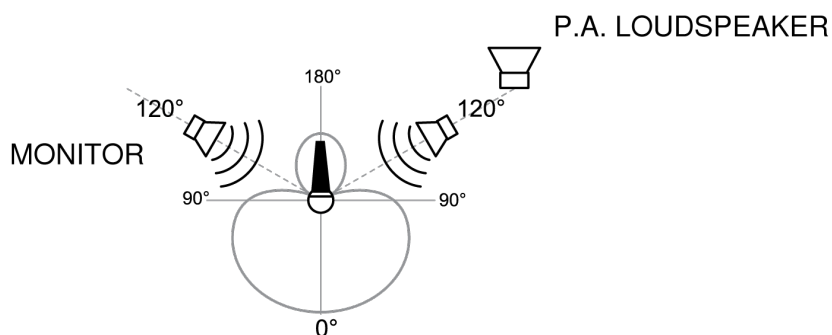

Recommended Loudspeaker Locations for Supercardioid Microphones

Proximity Effect

Unidirectional (cardioid) microphones progressively boost bass frequencies by 6 to 10 dB below 100 Hz when the microphone is at a distance of about 6 mm (1/4 in.) from the sound source. This phenomenon, known as proximity effect, can be used to create a warmer, more powerful sound. To prevent explosive low frequency sound during close-up use, the bass response gradually rolls off. This provides greater control and helps the user take advantage of proximity effect.

Specifications

Type

Dynamic (moving coil)

Frequency Response

50 to 16,000 Hz

Polar Pattern

Supercardioid

Output Impedance

290 Ω

Sensitivity

at 1kHz, open circuit voltage

-51 dBV/Pa (2.8 mV) [1]

Weight

Net

0.275 kg (0.6 lbs)

Connector

Three-pin professional audio (XLR), male, balanced

Housing

Silver blue enamel-painted die cast metal with hardened, matte-finished steel mesh grille

[1] 1 Pa=94 dB SPL

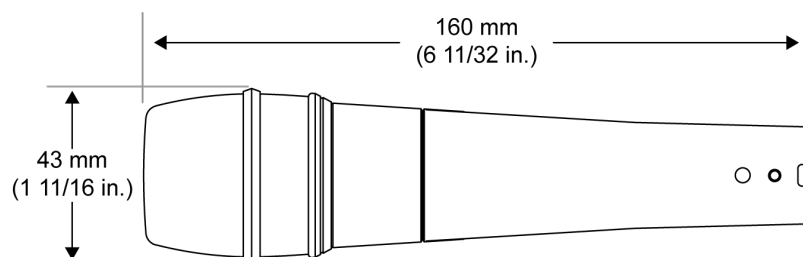

Overall Dimensions

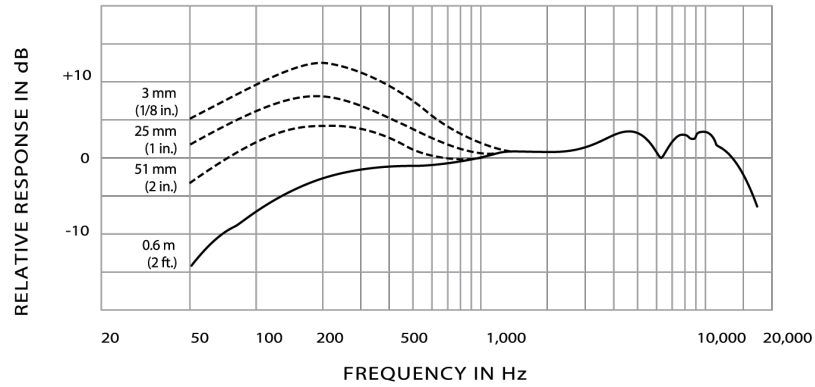

Typical Frequency Response

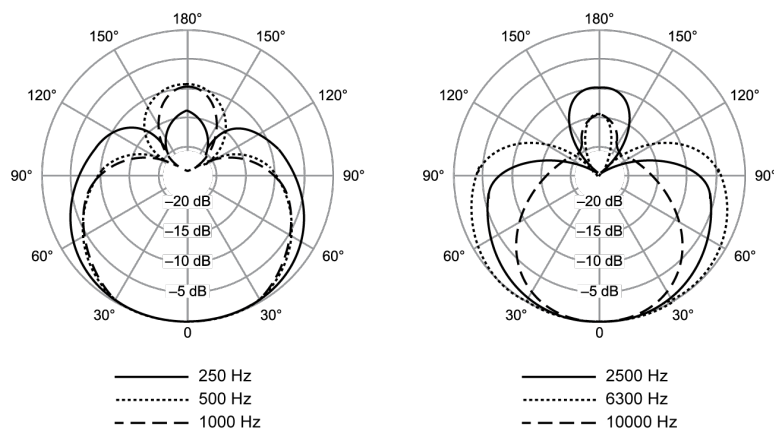

Typical Polar Pattern

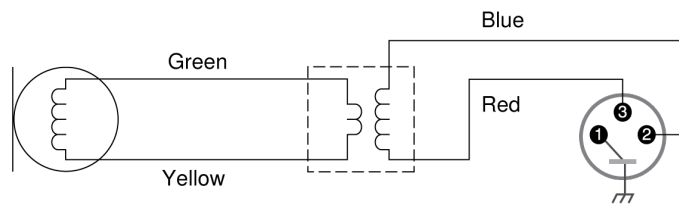

Wiring Diagram



Accessories

Furnished Accessories

Microphone Clip for SM58, SM57, SM87A, BETA87A, BETA87C, PGA57, PGA58, PGA48, PGA81	A25D
5/8" to 3/8" (Euro) Threaded Adapter	95A2050
Zippered Carrying Bag	95A2314

Optional Accessories

Black Locking Foam Windscreen for BETA57 and BETA57A	A57AWS
Shock Stopper® Isolation Mount	A55HM
25 foot (7.5m) Triple-Flex® Microphone XLR Cable with Switchcraft connectors	C25E

Replacement Parts

Cartridge for BETA56, BETA56A, and BETA57A	R174
Grille for BETA56A and BETA57A	RK320
Plug (Connector) Assembly	90J1984

Certifications

This product meets the Essential Requirements of all relevant European directives and is eligible for CE marking.

The CE Declaration of Conformity can be obtained from: www.shure.com/europe/compliance

Authorized European representative:

Shure Europe GmbH

Headquarters Europe, Middle East & Africa

Department: EMEA Approval

Jakob-Dieffenbacher-Str. 12

75031 Eppingen, Germany

Phone: +49-7262-92 49 0

Fax: +49-7262-92 49 11 4

Email: info@shure.de