

ARQA

User Guide

Arqa TX1/C

Arqa TX1/F

Arqa RX1/C

Arqa RX1/F



Engineering the **world's best** visual solutions

EXCELLENCE BY DESIGN

CONTENTS

UNPACKING	4-5
INTRODUCTION	5
HARDWARE	6
■ Arqa TX1	6
■ Arqa RX1	7
■ Status LED	8
■ Installing the Arqa TX1 and RX1 Extenders	9
■ Connecting the Arqa RX1/C and TX1/C Extenders	10-11
■ Removing a CATx Cable	11
■ Connecting the Arqa RX1/F and TX1/F Extenders	12-13
■ Removing a Fiber Cable	13
■ Replacing the SFP Module	14
■ Mounting Options	14
■ Optional Rack Mounting Kit (RMK)	15
■ Attaching the Arqa TX1 Extenders to the RMK	15
■ Fitting the Correct PSU Blade	15
SOFTWARE	16
■ Using the On Screen Display	16
■ Main Menu shortcuts	16
■ Status Overview	17
■ Defining what DDC Data your PC Uses	17
■ Available Devices	18
■ Managing Favourite Devices	19
■ Changing the Setting of your Arqa Units	19
■ Arqa TX1 Settings	19
■ VGA Parameters	20
■ Arqa RX1 Settings	21
■ Audio Input Gain = A	21
■ RS232 Baud rate = R	21
■ RS232 Connector Pinning	22

Arqa User Guide

■ Show the Last Received Image = S	23
■ Using the Power Save Mode = P	23
■ Selecting a Keyboard Layout = K	23
■ Changing the Keyboard Fallback Mode - O	23
■ Editing Keyboard Shortcuts = H	24
■ Hide Status Screen = N	24
NETWORK SETTINGS AND MANAGEMENT SWITCHING SYSTEMS	25
CONNECTING, DISCONNECTING OR SELECTING A CURRENT WORKPLACE CONNECTED DEVICE	25
■ Enabling a direct connection	25
TROUBLESHOOTING	26-28
■ Arqa RX1/TX1 LED Warnings	26-27
MAINTENANCE	29
ENVIRONMENTAL	30
■ CE	30
■ FCC	30
■ Disposal	30
SPECIFICATIONS	31
■ Arqa RX1/TX1	31
■ Arqa RMK	31
WARRANTY/RMA	32
■ Warranty Statement	32
■ RMA Returns Policy	32
■ Disclaimer/Copyright Statement	33
CABLE/NETWORK SWITCH REQUIREMENTS	34
■ Schema EIA/TIA-568 B	34
■ Fiber Cables	34
■ Multi-Mode	34
■ Single-Mode	35
RECOMMENDED NETWORK SWITCHES	36
INDEX	37

Arqa User Guide

UNPACKING

Your packing box should contain the following items:

- 1x Arqa TX1 unit
- or 1x Arqa RX1 unit

Transmitter Unit (Arqa TX1).

- 1 x wall power supply unit | 12V 1A (European or International plug)
- 1 x DVI - HDMI cable 1.8m/5.9ft
- 1 x USB cable 1.8m/5.9ft
- 2 x audio cables 1.8m
- 1 x DVI to HDMI adapter
- 1 x rubber feet (incl 4 pcs)
- 1 x mounting pad (incl 4 pcs)

Receiver Unit (Arqa RX1)

- 1 x wall power supply unit | 12V 1A (European or International plug)
- 1 x rubber feet (incl 4 pcs)
- 1 x mounting pad (incl 4 pcs)
- 1 x DVI to HDMI adapter

Fiber version only

- 2 x SFP 1G Multi-mode up to 500m. 1 x plugged into the device and 1 x in the box for far end connection to a switch



TX1/C

Rack Mount Kit (Optional)

- 1 x rack shelf
- 2 x mains power cables
- 1 x faceplate
- 1 x Redundant Power Supply Unit (RPSU)
- 1 x accessories bag containing faceplate fixing screws

If any of the items are missing, please contact Datapath for further instructions.

INTRODUCTION

Congratulations on the purchase of your new Datapath Arqa TX1/RX1 unit. The unit has been manufactured and tested to the highest standards offering unparalleled quality and reliability. The aim of this user guide is to assist you through the installation of the Arqa units safely and effectively and act as a reference guide for future use.



RX1/C



RX1/F

HARDWARE

Arqa TX1

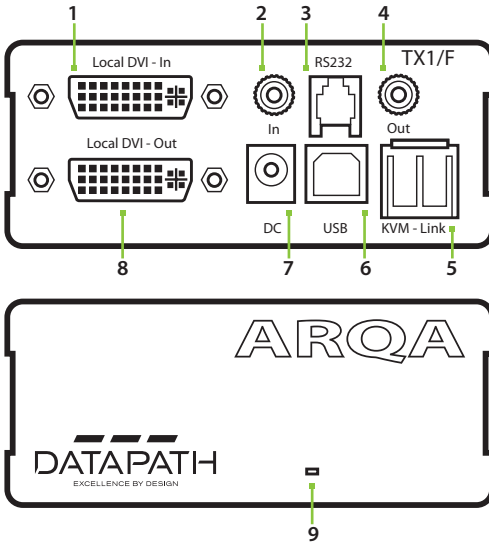

1	Local DVI-in	DVI connection to PC. DVI-I (VGA also supported).
2	In	Audio in from PC.
3	RS232	RS232 connection.
4	Out	Audio out to PC.
5	KVM-link	Connection for CAT5/6/7 cable or fiber cable (SFP module).
6	USB	USB connection.
7	DC	12V power supply connection.
8	DVI-out	DVI connection to a monitor (optional).
9	Power/Status LED	Displays the status of the unit.

Arqa User Guide

Arqa RX1

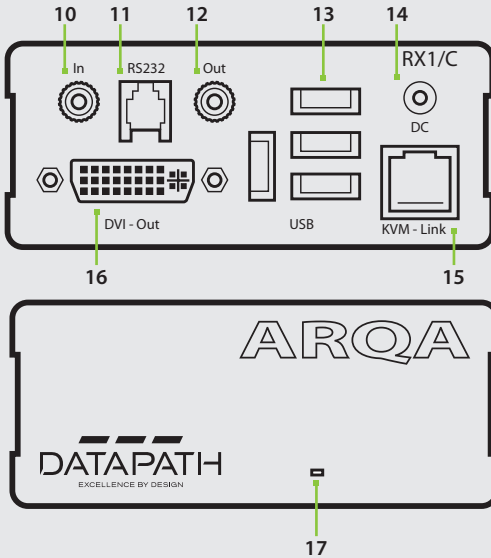

10	In	Audio in from microphone.
11	RS232	RS232 connection.
12	Out	Audio out to speakers.
13	USB	USB connections (keyboard and mouse).
14	DC	12V power supply connection.
15	KVM-link	Connection for CAT5/6/7 cable or fiber cable (SFP module).
16	DVI-out	DVI-D connection to a monitor.
17	Power/status LED	Displays the status of the unit.

Arqa User Guide

Status LED

The status LED can illuminate Red, Orange or Green.

The table below displays the meaning of each colour.

Colour	Blinking	Physical Link	Active Connection	Video Extended	USB Initialisation	USB Data Received	Identify Command	Auto update Mode
Red	-	Yes	No	No				Update failed
Red	Slow	No	No	No				
Orange	-	Yes	Yes	No				
Orange	Fast							Update in progress
Green	-	Yes	Yes	Yes				Update succeeded
Green	V. fast				Yes**			
Red/Green	V. fast						Yes	
RJ45 Socket LEDs*								
Yellow	-	No						
Yellow	Slow	Yes						
Green	-			Yes				
Green	V. fast					Yes		

* Arqa TX1 only

** Arqa RX1 only

Arqa User Guide

Installing the Arqa TX1 and RX1 Units

The units can be set up to access one host computer, or to access numerous host computers. In the case of the latter, an additional Network Switch must be installed. With a Network Switch, each user can gain quick access to any of the required PCs.

Single Point-to-Point Connection

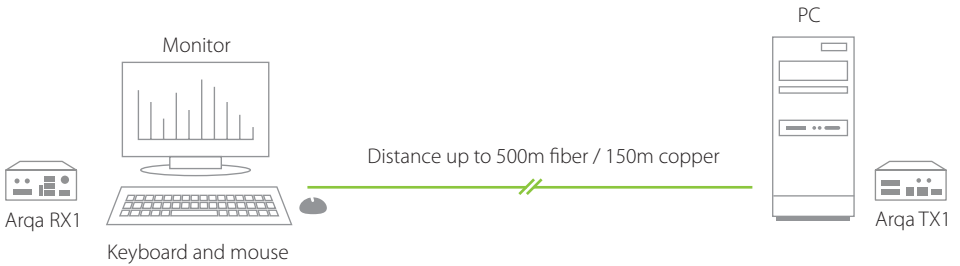

Setting up an IP Matrix Switching System

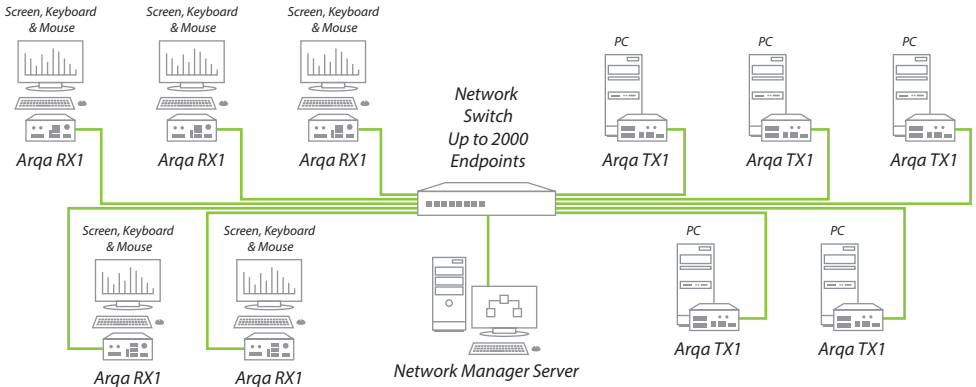

Arqa User Guide

Connecting the Arqa RX1/C and TX1/C Copper Units

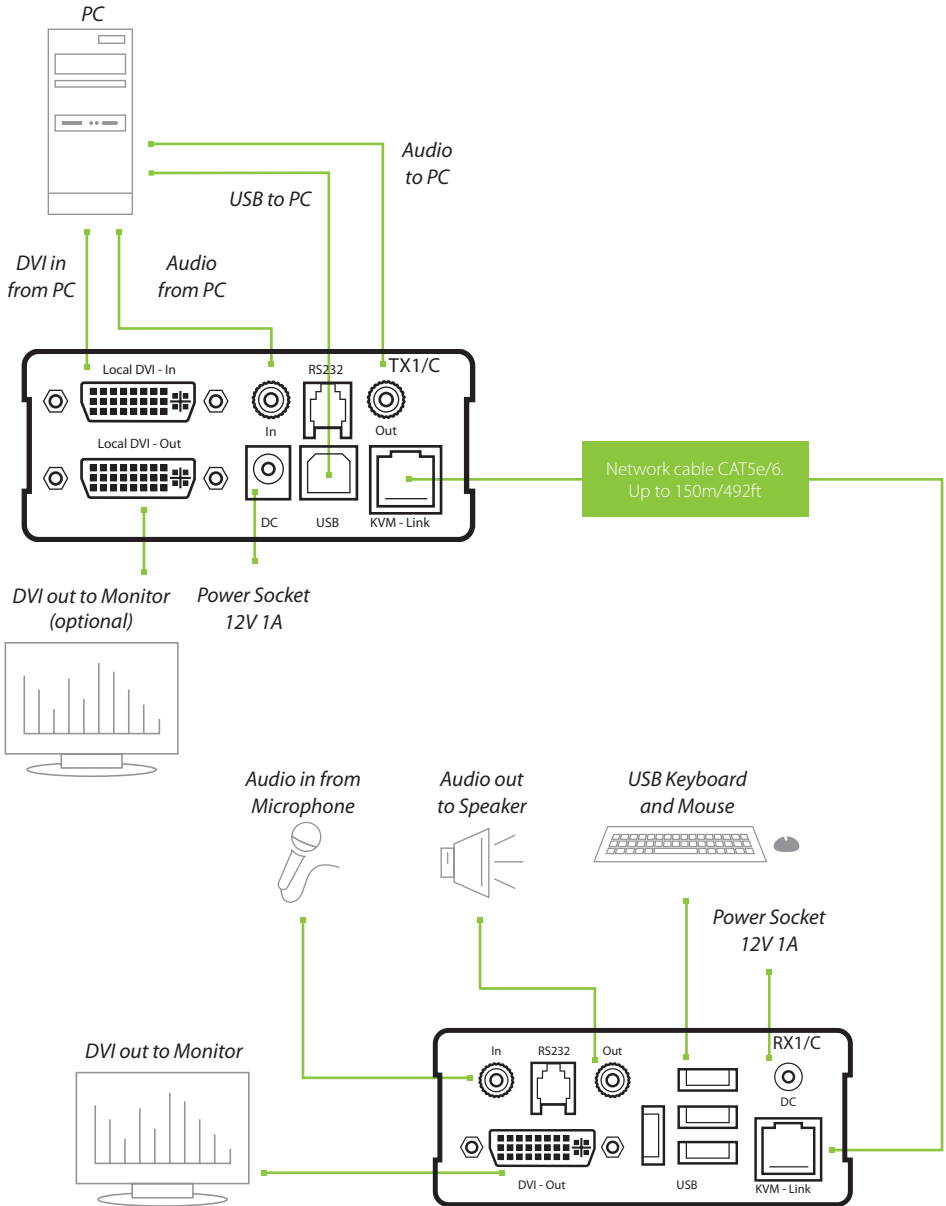

Arqa User Guide

Connect the Arqa RX1/C and the TX1/C as follows using the connection illustration as a guide:

- Connect both the Arqa RX1/C and the TX1/C to the 12V 1A power supply provided.
- Connect the USB cable (provided) to a USB port on the PC and to the USB port on the Arqa TX1.
- Connect a keyboard and mouse to the USB ports on the Arqa RX1.
- Connect the Arqa RX1/C and TX1/C using a CAT5e/6 cable (not supplied).
- Connect the Arqa RX1/F and TX1/F using a fiber cable (not supplied) connected to the SFP modules in each unit.
- Connect the graphics output of your PC to the DVI In port of the Arqa TX1 using the supplied HDMI to DVI video cable. ■ Connect a keyboard and mouse to the USB ports on the Arqa RX1.
- Connect the DVI Out port of the Arqa TX1 into a local monitor if required. You can use the supplied DVI/HDMI adapter to reconnect your original HDMI cable back into the HDMI input of your local monitor.
- Connect the Arqa RX1 DVI Out port to the remote monitor using the video cable supplied with your monitor and the DVI/HDMI adapter supplied with your RX1 receiver.
- If using a network switch, connect all endpoints from the units to the switch. Ensure that all connections have a minimum bandwidth of 1 Gbit/sec. For video sharing the network switch must support IGMP snooping.

Removing a CATx Cable

To remove a CATx cable:

- Press the latch down and slowly pull the cable out.

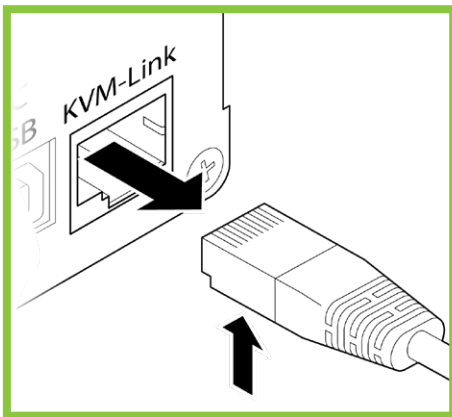

Connecting the Arqa RX1/F and TX1/F Optical Units

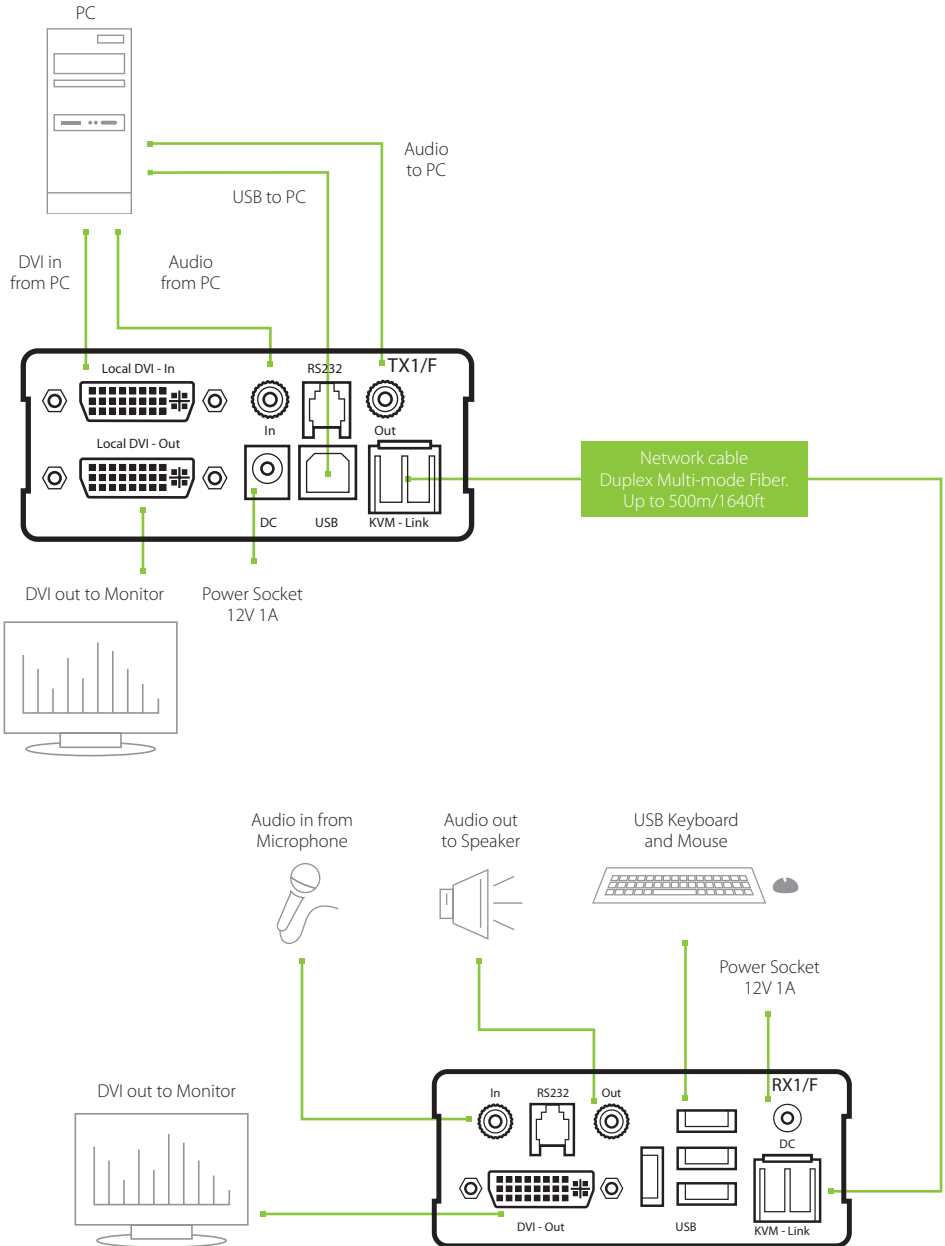

Arqa User Guide

Connect the Arqa RX1/F and the TX1/F as follows using the connection illustration as a guide:

- Connect both the Arqa RX1/F and the TX1/F to the 12V 1A power supply provided.
- Connect the USB cable (provided) to a USB Port on the PC and to the USB port on the Arqa TX1/F.
- Connect a keyboard and mouse to the USB ports on the Arqa RX1/F.
- Connect the Arqa RX1/F and TX1/F using a fiber cable (not supplied) connected to the SFP modules in each unit.
- Connect the supplied DVI cable to the DVI output on the PC to the DVI input on the Arqa TX1/F.
- Connect a monitor to the DVI - out socket on the Arqa TX1/F.
- If using a network switch, connect all endpoints from the Arqa units to the switch. Ensure that all connections have a minimum bandwidth of 1 Gbit/sec. For video sharing the network switch must support IGMP snooping.

Removing a Fiber Cable

To remove a fiber cable:

- Press the latch down and slowly pull the cable out.

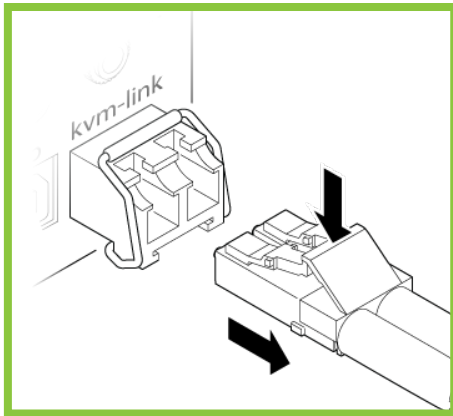

Arqa User Guide

Replacing the SFP Module

The Arqa RX1/F and TX1/F are supplied with 2 SFP modules. One is installed and one is provided for the endpoint module:

To replace the SFP:

1. Remove the black dust protector from the SFP module.
2. Pull the metal lever down until it reaches an angle of 45 degrees and gently slide out the module.
3. Insert the required module and lock into place by pushing the locking lever up into the locked position.

Note: We recommend the use of SFP modules supplied by Datapath Ltd.

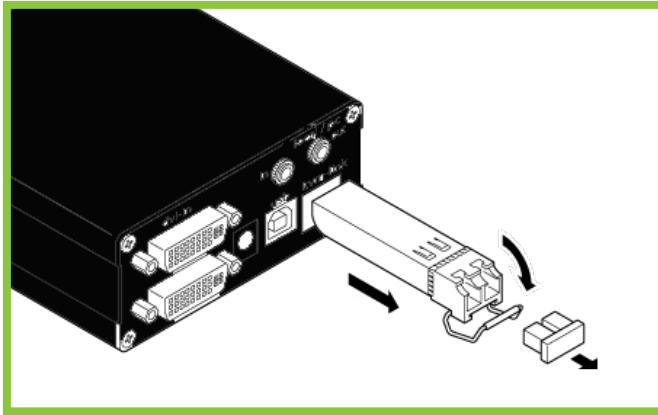

Mounting Options

Mounting Pads and Feet

The mounting pads and rubber feet can be used to hold the units in place and prevent them from sliding on most surfaces.

To attach the mounting pads or rubber feet:

- Remove the protection layer from the mounting pads or rubber feet.
- Attach the mounting pads or rubber feet to the base of the unit.

Arqa User Guide

Optional Rack Mounting Kit (RMK)

The Rack Mounting Kit is used to mount up to 4 x Arqa TX1 units. It is equipped with rack shelf, faceplate and an RPSU.

Attaching the Arqa TX1 Units to the RMK

Attach the Arqa TX1 to the faceplate by removing the top left and bottom right screws **(1)**. Align the blank screw holes on the faceplate **(2)**, then insert the screws to lock the Arqa TX1 units in place.

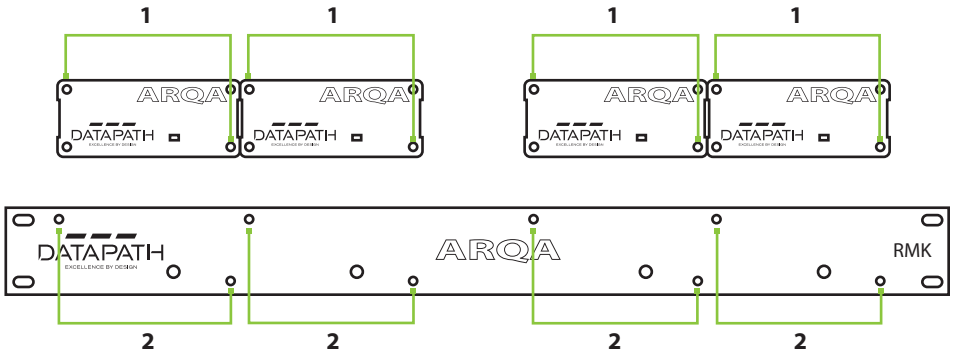

Fitting the Correct PSU Blade

The power supply unit is shipped with International and European blades to enable access to the local power supply. To remove a blade, first press the blade release catch and then slide the blade upwards.



SOFTWARE

This chapter will cover:

- Introduction to the On Screen Display (OSD).
- A summary of Arqa Network Manager features.
- Introduction to Arqa Network Manager.

Using the On Screen Display

The On Screen Display (OSD) is a software tool built into your Arqa RX1 providing a number of functions. To access the On Screen Display, connect a monitor and keyboard to your Arqa RX1

Press the Scroll key on your keyboard quickly a minimum of five times.

The main OSD is displayed listing a number of sub-

menus, each sub-menu has a corresponding short cut key as indicated on the left. To open a sub-menu, press the short cut key on your keyboard.



Main Menu shortcuts:

Key	Sub Menu	Summary
T	Status Overview	Displays the current status of the unit you are connected to.
O	DDC Option	Define what DDC information is used by the PC.
L	List and Connect to KVM sources	List of devices you can connect to.
F	Show Favourites	List of selected favourite devices (max of 8).
S	Show Share Devices	List of devices available to share with other Arqa RX1 units.
G	System Settings menu	Access to change a range of unit preferences.
P	Point-To-Point Mode	Enable/disable.
A	Login Form	Change login settings.
Q	Exit	Exit the On Screen Display.

Arqa User Guide

Status Overview

In the status overview menu the current status of the unit connection is displayed. It provides information on the current version of the firmware, the connection, the resolution of the video channel, and USB status.

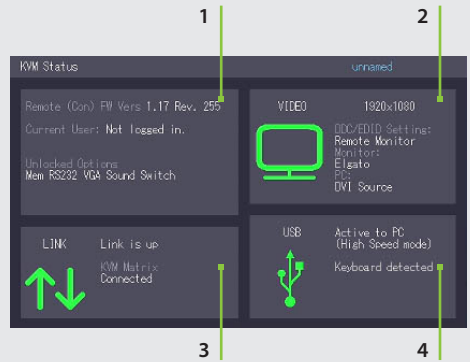

1	Displays the enabled options and the current version of the firmware. Firmware version is also displayed on the main OSD menu page.
2	Video - displays information of the video data currently being transmitted.
3	Link Status - shows if a physical connection is available. Connected indicates KVM data can be transmitted.
4	USB - displays USB connection data.

Updating firmware is carried out using **Update Management** page in the **Arqa Network Manager Systems** tab. Full instructions on how to update your firmware can be found in the **Network Manager User Guide**.

Setting the transmitters EDID

When this option is set to **Remote Monitor** the Arqa devices will read the EDID data from the display connected to the RX1 device and send it back to the source that is currently connected to the TX1. Once the source receives EDID data, the display driver in the source can decide what resolution to output based on the information it has received from the display. This process typically takes a few seconds to complete and is the same process that occurs every time a monitor is switched on or a video cable is re-connected.

Therefore, in this mode each time a network connection is made to a new source, the system will repeat the EDID communication. The advantage of this mode is that a source will always output the preferred resolution of the monitor that it is viewed on, but a disadvantage is that the switching time can be high.

For that reason it may be preferable to use one of the **FIX** options by fixing the EDID presented by the transmitter. This ignores the display's EDID and always asks for the same resolution from the source. Practically in any system where multiple sources and displays all have the same preferred resolution, using one of the **FIX** options may be a better approach. For example, using **FIX 1920 x 1080** might be practically the best option, since this is a mode that nearly all modern displays can support. When using a **FIX** option, EDID pass-through is bypassed and switching time is much lower.

Open the OSD main menu by quickly pressing the **Scroll key** a minimum of 5 times. In the main on screen menu, press the **O** key.

Arqa User Guide

When selecting the EDID of the remote monitor users must ensure the monitor is not [Field]4K capable as the Arqa unit is only designed to carry HD and not 4K.

Note: If left at the default setting of 'remote monitor' and plugged into a 4K capable display, Arqa will not work!

Choose which DDC or EDID information your PC uses.

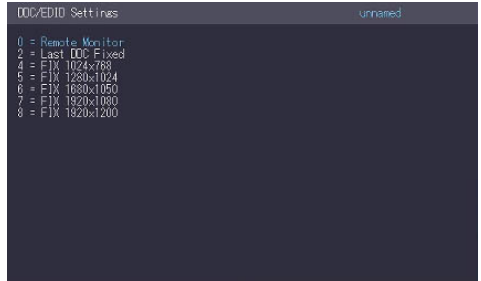

- Press **0** to use the DDC information from the monitor attached to the remote unit.
- Press **2** to save the current DDC information.
The unit uses the same settings after the unit has been restarted.
- Press **4** through **8** to use a predefined resolution which is saved.
- Press **ESC** to go back to the main menu.

Available Devices

The devices you can connect to and share are listed on the **Device List** menu. To access the menu, open the 'OSD main menu' by quickly pressing the **Scroll key** a minimum of 5 times, then press the **L** key.

Use the up/down cursor keys to:

- Select a device, press **ENTER**.
- Remove a device from your favourite list press **DELETE**.
- To enter device filter press **TAB** then press **ENTER** to apply the filter.
- Press **ESC** to exit the Share Device List page.



Arqa User Guide

Managing Favourite Devices

To access the **Show Favourites** menu, open the OSD main menu by quickly pressing the Scroll key a minimum of 5 times, then press the **L** key.

A total of eight favourite devices can be defined and connected to by pressing a keyboard shortcut (1-8).

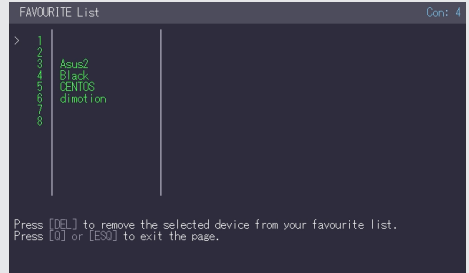

Changing the Setting of your Arqa Units

The Arqa Unit settings menu allows you to change a range of settings in your Arqa RX1 or Arqa TX1 units. To access the settings menu, open the **OSD** main menu by quickly pressing the Scroll key a minimum of 5 times, then press the **G** key. The following menu is displayed:

Select which settings you wish to change, Transmitter Settings (Arqa TX1) or Receiver Settings (Arqa RX1).

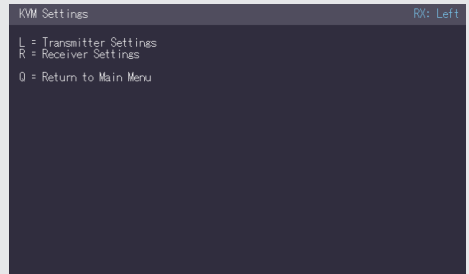

Arqa TX1 Settings

From the KVM Settings menu, press the **L** key. The Transmitter Settings (Arqa TX1) menu appears.

Select **VGA Parameters** and a new OSD menu is displayed. The **USB Compatibility Mode**, **Enable USB Remote Wakeup** and **Compatibility with Linux** options can all be toggled either **Enable** or **Disable**.

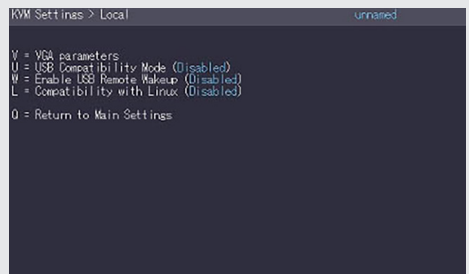

Arqa User Guide

VGA Parameters

To access the VGA parameters menu, press the **V** key and the following dialogue is displayed:

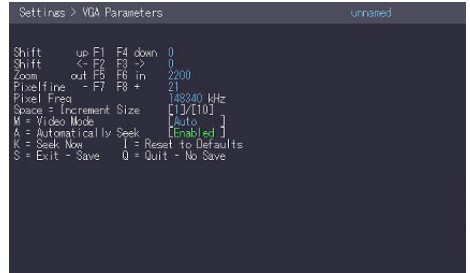

- Press **F1** to move the display area up.
- Press **F4** to move the display area down.
- Press **F2** to move the display area to the left.
- Press **F3** to move the display area to the right.
- Press **F5** to zoom out.
- Press **F6** to zoom in.
- Press the **Space** bar to change the rate of the above-mentioned setting. This toggles the rate of change between 1 and 10.
- Press **M** to switch the video mode between:
 - **Auto** – the mode is automatically detected and set by the unit.
 - **DVI** – only DVI input is detected.
 - **VGA** – only VGA input is detected.
- Press **K** for automatic adjustment and positioning of the image area.
- Press **I** to reset parameters to default values.
- Press **S** to save the settings and exit the menu.
- Press **Q** to exit without saving.

Arqa User Guide

Arqa RX1 Settings

From the KVM Settings menu, press the **R** key. The **Receiver Settings** (Arqa RX1) menu appears.

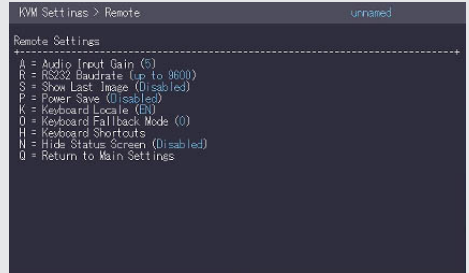

Audio Input Gain = A

The volume of the audio input (microphone) on the remote unit can be changed. The default value is 5 but can be set to any value in between 0 and 9. At 0 the audio input on the remote unit is disabled.

Setting the volume:

Press the **A** key and the **Audio Input Gain** menu is displayed:

- Press **Left / Right** arrows to change volume.
- Press arrow **Up / Down** to set the direction of the volume: Arqa TX1 to Arqa RX1 or Arqa RX1 to Arqa TX1.

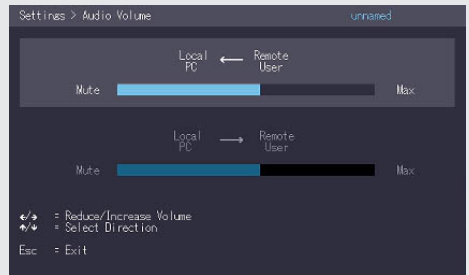

RS232 Baud rate = R

Setting the baud rate with activated RS232 upgrade. Press the **R** key and the **RS232** menu is displayed

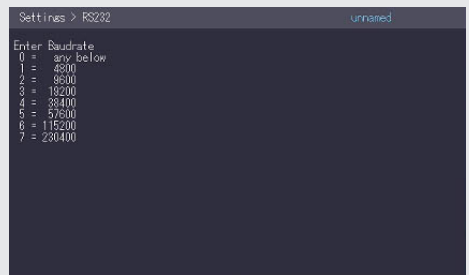

Arqa User Guide

To select a baud rate, press the corresponding key and the Enter Parity menu is displayed:

Press the appropriate key to select a parity.

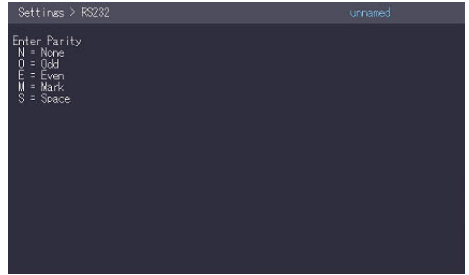

RS232 Connector Pinning

TX1 Pinout (DCE)		
Pin	Function	Direction
2	TxD	OUT
3	RxD	IN
4	DTR	IN
5	GND	-
8	CTS	OUT

TX1 Pinout (DCE)		
Pin	Function	Direction
2	RXD	IN
3	TXD	OUT
4	DTR	OUT
5	GND	-
8	CTS	IN

The pin numbers refer to a 9-pin D-sub plug.

The baud rate can be set in the menu. There is a universal setting for baud rates up to 9600 which transmits all different RS232 configurations transparently. For higher baud rates the following settings are available.

Possible Baud rate
4800
9600
19200
38400
57600
115200
230400

Possible Parity
No
Odd
Even
Mark
Space

Possible Stop bits
1
2

Arqa User Guide

Show the Last Received Image = S

Users can select what is displayed on the monitor connected to the Arqa RX1 unit when it is disconnected from and Arqa TX1.

If the **Show Last Image** feature is disabled, a black screen is displayed. If enabled, the last image received before the unit was disconnected is shown.

From the KVM Settings menu > Arqa RX1 menu press **S** to **Enable** or **Disable**.

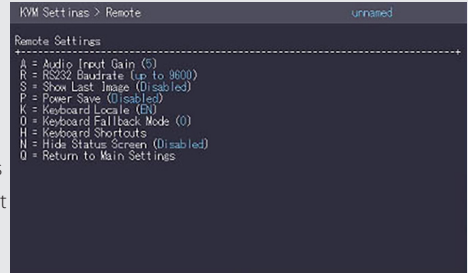

Using the Power Save Mode = P

Power save mode can be enabled or disabled on the Arqa RX1 unit. If enabled, the unit will go into power save mode should the Arqa RX1 not receive data from the Arqa TX1 for a period exceeding 1 minute.

If the Arqa RX1 is configured to **Show Last Image**, when the system becomes disconnected, the image is displayed for a period of one minute and will then enter power save mode.

To wake the system up from power saving mode, press any key.

Selecting a Keyboard Layout = K

The **Keyboard Locale** menu enables the user to select one of three keyboard layouts for use when navigating the On Screen Display menu. The choices are French (Azerty), English (Qwerty) and German (Qwertz).

To select the required keyboard layout press **K** in the **KVM Settings > RX1 menu** and the **Keyboard Locale** menu is displayed.

- Press **E** to select English (Qwerty)
- Press **D** to select German (Qwertz)
- Press **F** to select French (Azerty)

Changing the Keyboard Fallback Mode – O

USB Keyboards have to be identified by the **Arqa RX1** to enable the user to use the **On Screen Display** menu. For most keyboards use setting **0**. There can be instances when some USB mouse devices behave like a keyboard, in this instance select fallback mode **1** or **2**.

Arqa User Guide

Editing Keyboard Shortcuts = H

The OSD menu allows the user to create and edit keyboard shortcuts for selected common commands. The scroll speed can also be configured.

To edit the keyboard shortcuts press **H** in the **KVM Settings > Arqa RX1 menu** and the **Keyboard Shortcut** menu is displayed:

Use the keyboard cursor arrows to select a command.

Press **E** to edit the shortcut.

To edit:

Press a single key. Edit the frequency with left and right arrows

or

Press a key combination.

Hide Status Screen = N

The Hide Status Screen allows the user to hide the screen status dialogue. By enabling, the Status Screen dialogue is removed, and the display remains black.



Arqa User Guide

Network Settings and Management Switching Systems

All network settings, user administration and system management are configured using the Arqa Network Manager software application which can be purchased from the Datapath sales team. All functions are described in the Network Manager User Guide. You can download the user guide from our website www.datapath.co.uk.



Connecting, Disconnecting or Selecting a Current Workplace Connected Device

To log in to the local PC in the main OSD menu, press **A**.

Enter your username and password.

To disconnect from an encoder in the main OSD menu, press **D**.

Enabling a direct connection

If you are not connected through a network switch, you can connect directly to an encoder with Point-to-Point mode.



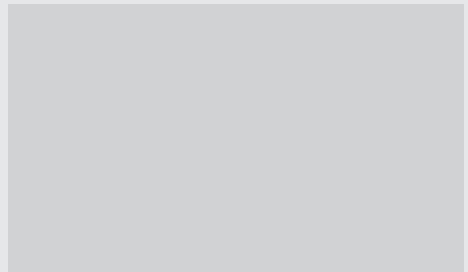
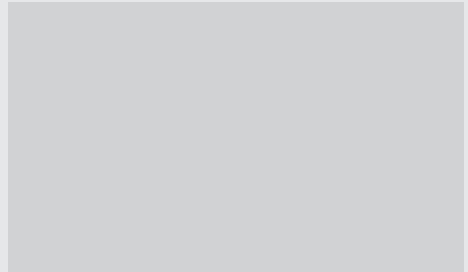

In the main OSD menu, press **P**.

After logging in, the user receives personalised lists (Devices, Favourites List).





TROUBLESHOOTING

Arqa RX1/TX1 LED Warnings

	LED	Cause	Solution
	LED does not illuminate	No Power.	Check Power supply unit is connected.
	LED displays Red	No connection between the Arqa TX1 and RX1.	Check if the RJ45/network cable is connected. A clicking noise should be heard when plugging it in.
	LED displays Orange	Image not displayed on monitor.	<p>Check all connections from the Arqa TX1 to the local PC.</p> <p>Check if the Arqa RX1 (monitor) cable is connected correctly.</p> <p>If everything is connected well but no function appears, reconnect power supply again.</p> <p>If the On Screen Display is visible, select the 'O' option and choose the resolution of the monitor. Then press the assigned number on your keyboard.</p>
	LED displays Green	Keyboard not working.	<p>Unplug the keyboard and reconnect, wait until the driver is installed (after few seconds).</p> <p>Check all USB connections on both sides (Arqa TX1 and RX1).</p> <p>If it is still not working, unplug then plug in the power supply.</p>
	LED displays Green	No audio.	<p>Establish audio connection:</p> <p>Plug stereo-jack to the audio output of the PC (green) and connect to the 'In' socket on the Arqa TX1. Connect the Arqa RX1 'Out' to the speaker/headset.</p> <p>Establish microphone connection:</p> <p>Plug stereo-jack to the microphone input of the PC (pink) and connect to the 'Out' socket on the Arqa TX1. Connect the Arqa RX1 'In' to the microphone.</p>

Arqa User Guide

	LED displays Green	The screen flickers or has an abnormal display.	Download and install the latest firmware from the Datapath website.
	LED flashing Green	The Arqa RX1 and TX1 have different firmware installed or the USB is not compatible.	Contact the Datapath Support Team.
	LED are lighting differently	The Arqa RX1 and TX1 may have different firmware installed.	Enter the On Screen Display to confirm the firmware versions. To open the On Screen Display press the Scroll Lock Key a minimum of five times in quick succession. The firmware version is displayed below the menu. Should a firmware update not work, contact the Datapath Support Team.

Arqa User Guide

No power (No LED)

Ensure Unit is connected to a mains supply.

Check the Power Supply Unit in another unit.

Reprogramme unit using a JTAG programmer.

Contact Datapath Support (see Warranty/RMA).

Check the USB cable from the Arqa TX is connected to the PC.

Please Note: If a problem persists with your Arqa RX1/F or TX1/F, please ensure the Datapath SPF modules supplied with your unit(s) are fitted prior to contacting Support.

USB not working

Ensure USB devices are plugged in correctly.

Check the USB cable from the Arqa TX is connected to the PC.

Do the USB devices work when connected directly to the PC?

Replace the USB cable from the Arqa TX1 to the PC.

Ensure the Arqa RX1 / TX1 have the same firmware.

Swap the Arqa RX1, then the TX1 with another unit.

Contact Datapath Support (see Warranty/RMA).

No video displayed

Ensure all cables are plugged in correctly.

Check the PC is outputting a signal. Connect a display to the DVI-out in the Arqa TX1.

Ensure the DDC is correctly set in the On Screen Display. (option O).

Ensure the Arqa RX1 / TX1 have the same firmware.

Contact Datapath Support (see Warranty/RMA).

Video error (stripes across the image)

Ensure all cables are plugged in correctly.

Check the PC is outputting a signal. Connect a display to the DVI-out in the Arqa TX1.

Ensure the DDC is correctly set in the On Screen Display. (option O).

Ensure the Arqa RX1 / TX1 have the same firmware.

Check Network Switch is set up correctly and has enough bandwidth capacity.

Swap the Arqa RX1 and the TX1 with another units to see if the error remains.

Contact Datapath Support (see Warranty/RMA).

MAINTENANCE

The Arqa RX1 and TX1 require very little maintenance. However, care should be taken to keep all connectors free from dust and not allow any fluid ingress.

Do not use cleansers containing solvents, alcohol wipes or spirit based chemicals to clean your extenders as it could cause damage to the surface.

If a problem persists with your Arqa RX1/F or TX1/F, please ensure the Datapath SFP modules supplied with your units are fitted prior to contacting Support.

ENVIRONMENTAL

Certification and Compliance

CE



EU- Class A Declaration of Conformity

Datapath Ltd declares that this Arqa KVM extenders complies with the essential requirements and other relevant provisions of Directives 2014/30/EU, 2014/35/EU and 2011/65/EU.

A copy of our Declaration of Conformity is available on request:

Datapath Ltd
Bemrose House
Bemrose Park
Wayzgoose Drive
Derby, DE21 6XQ
United Kingdom

FCC

The Datapath Arqa extenders comply with part 15 of the FCC Rules. Operation is subject to the following two conditions: (1) These devices may not cause harmful interference, and (2) these devices must accept any interference received, including interference that may cause undesired operation.

This equipment has been tested and found to comply with the limits for a Class A digital device, pursuant to part 15 of the FCC Rules. These limits are designed to provide reasonable protection against harmful interference when the equipment is operated in a commercial environment. This equipment generates, uses and can radiate radio frequency energy and, if not installed and used in accordance with the instruction manual, may cause harmful interference to radio communications. Operation of this equipment in a residential area is likely to cause harmful interference in which case the user will be required to correct the interference at their own expense.

Disposal

At the end of life, all Datapath products should be disposed of as per local laws and regulations dictate. In the UK, contact Datapath to arrange disposal. Our WEEE registration number is WEEE/AA0005ZR.

Arqa User Guide

SPECIFICATIONS

Dimensions	W 97.5mm x D 103.5mm x H 41mm
Weight	Arqa TX1 302g Arqa RX1 291g
Operating Temperature	0 - 35 °C / 32 - 96 °F
Power Supply Input Voltage	100 - 240 V / 50/60 Hz AC
Power Requirements	6W per extender (excluding attached USB devices)
Storage Temperature	-25 to 80 °C / -13 to 176 °F
Relative Humidity	80% non-condensing
MTBF	82,820 hrs / 9 years

Arqa RX1/TX1

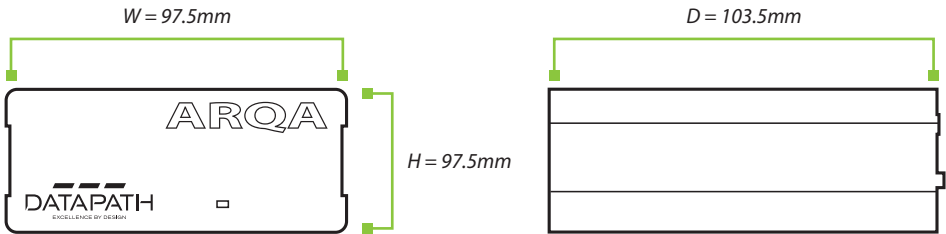

Arqa RMK



WARRANTY/RMA

Warranty Statement

Datapath provides a return to manufacturer warranty on all its products for a standard 36 month period. It is important that RMA procedures are followed prior to products being returned as often issues can be resolved quickly without the need for products being returned.

RMA Returns Policy

If your Datapath product is not working as you expect, we recommend that you contact Datapath Ltd in the first instance for support. Many issues that may first appear as hardware faults are actually installation or set-up problems and can normally be resolved without having to ship any hardware back to us. This route is therefore often the quickest, easiest and cheapest way of solving the problems that you are experiencing. Please email **support@datapath.co.uk** including as much detail regarding the failure as possible (for example: system description, signal types, input or output resolutions and any other relevant background information).

It is essential for you to know the serial number of the product(s) when contacting us.

If it appears that the fault is most likely to be hardware related, please email **rma@datapath.co.uk** stating the serial number and as much additional information regarding the nature of the failure as possible. Detailed explanation of the fault will help us to better identify the problem and will direct additional focused testing if necessary. We will then issue an **RMA Number** to you.

At the time that the **RMA Number** is issued we will inform you of the warranty status of the product and the cost of the repair - see paragraph (b) below. The product should then be returned, at your cost, to Datapath Ltd following the steps below.

There are 4 possible scenarios when a product is returned to us:

- (a) The product is in warranty and is either found to be genuinely faulty or no fault is found. In these cases, the product will be repaired as necessary or replaced by a new or previously repaired product and returned to you at our cost.
- (b) The product is out of warranty and is found to be faulty. The product, if possible, will be repaired or replaced at fixed cost, as stated in the RMA authorisation email. To cover this payment you will be required to either provide a Purchase Order or Credit Card details when the product is returned to us (we will not issue an invoice or charge the credit card until the repair has been completed and is about to be returned to you).
- (c) The product is in warranty but is found to be damaged by misuse. This will be treated as (b) above.
- (d) The product is out of warranty and is obsolete. In the unlikely situation that the product can be neither repaired nor replaced, because some of its components are obsolete and we have no swap-out stock left, then the product will either be returned to you or disposed of at your request with no charge.

Arqa User Guide

Please Note: Datapath will not accept responsibility for the safety, integrity or security of any programmes, data or other content held on hard drives or any other type of rewritable media which is sent to us either separately or as part of any equipment returned to us for repair or for any other purpose. Customers are advised to take back-ups of anything that they deem to be valuable or important before returning the equipment to us and anything which is confidential should be erased from the media before it is returned.

Once the RMA Number has been issued, you need to raise your Purchase Order, or supply your credit card details, and return the product to: Datapath Ltd, Bemrose House, Bemrose Park, Derby DE21 6XQ, United Kingdom. Securely package the item and include the RMA Number clearly displayed on the outside of the box. To prevent unnecessary carriage and handling please only send back products or accessory items you believe to be faulty.

In the case of paragraph (c), the fixed charge will be levied after we have seen the product and identified the misuse. In this case, we will request you to issue a purchase order or provide credit card details before any repairs are completed.

Our policy is to return the repair (or swap-out) to you within 10 days of receipt.

Disclaimer/Copyright Statement

© Datapath Ltd, England 2019

Datapath Limited claims copyright on this User Guide. No part of this User Guide may be reproduced, released, disclosed, stored in any electronic format, or used in whole or in part for any purpose other than stated herein without the express permission of Datapath Limited.

Whilst every effort is made to ensure that the information contained in this User Guide is correct, Datapath Limited make no representations or warranties with respect to the contents thereof, and do not accept liability for any errors or omissions.

Datapath reserves the right to change specification without prior notice and cannot assume responsibility for the use made of the information supplied. Datapath Limited acknowledges all registered trademarks used within this User Guide.

CABLE/NETWORK SWITCH REQUIREMENTS

A Cat5e/6/7 cable should meet the following requirements:

- The pins are connected 1:1.
Caution: the cable pairs must be twisted to EIA/TIA- 568A (rare) or EIA/TIA-568 B (common) pairs.
- Erroneous assignments cannot be found with a simple cable tester.
- The pins for the green pair of wires are not adjacent to one other.
- The cable must at the very least meet the CAT5 specifications and be suitable for Gigabit transmission.
- The cable should meet one of the following standards: Class D ISO/IEC 11801:2002 or EN 50173-1:2002. Schema EIA/TIA-568 B.
- Use shielded installation cable with minimum cross section of 24 AWG throughout the total length.
- The shield should be continuous and connected to both ends. A shielded patch cable is allowed for connection to the device.

Schema EIA/TIA-568 B



	Pin	Colour
	1	Orange/White
	2	Orange
	3	Green/White
	4	Blue
	5	Blue/White
	6	Green
	7	Brown/White
	8	Brown

Fiber Cables

Multi-Mode (Standard)

A Multi-mode fiber cable should meet the following requirements:

- Maximum length should be 500m. The Arqa RX1/F and TX1/F include a fiber Multi-mode – SFP module which allows a transmission distance of up to 500m.
- Dedicated fiber connection cable type Duplex Multi-mode 50/125μ (OM2), LC connector.

Arqa User Guide

Single-Mode

A fiber Single-mode – SFP module cable should meet the following requirements:

- Up to 20 km transmission distance.
- Requires dedicated fiber connection: cable type Duplex Single-mode with LC connector.

A fiber Single-mode – SFP module BiDi cable should meet the following requirements:

- Up to 20 km transmission distance.
- Requires dedicated fibre connection: cable type Single-mode with LC connector wavelength (λ) of 850 nm in Multi-mode or 1310 nm TX -1550 nm RX in Single-mode.

Note: SFP modules included with Arqa are multi-mode and are not compatible with single-mode operation.

Customers can choose to purchase their own appropriate SFP modules if single mode distances are required.

Recommended Network Switches

RECOMMENDED NETWORK SWITCHES

Arqa's visually lossless video quality transmission requires a bandwidth of up to 900 Mb/s per port of the network switch.

It is HIGHLY recommend that users create a dedicated video distribution network for Arqa devices with its own network switch. Users should not attempt to connect other devices into the same network as this may cause unpredictable traffic issues.

Having other devices connected to the Arqa video distribution network is not a Datapath supported configuration, since it will likely result in non-deterministic behaviour.

Although the following switches are tested, other switches should work as long as they meet the following requirements:

- 1 Gb switch, with true non-blocking transfer rates of 1Gb/s on each port.
- IGMP Snooping must be enabled (v2 or higher).
- IGMP Fast-leave enabled.

The following list of switches have been tested and validated to work with the Arqa RX1 and TX1.

Item Number	Product
CATx Switches	
NS8RJ/2SFP	Network Switch 8x RJ45 1000 Base-T / 2x SFP 1G
NS24RJ/4SFP	Network Switch 24x RJ45 1000 Base-T / 4x SFP 1G
NS24RJ/2SFP+/2SFP+	Network Switch 24x RJ45 1000 Base-T / 2x SFP 1G / 2x SFP+ 10G
NS48RJ/4SFP+	Network Switch 48x RJ45 1000 Base-T / 4x SFP+ 10G
NS48RJ+/2SFP+	Network Switch 48x RJ45 10G / 2x SFP+ 10G
Fiber Switches	
NS24SFP/4SFP+	Network Switch 24x SFP/4x SFP+
NS48SFP/4SFP+	Network Switch 48 x SFP/4x SFP+ with redundant power supply
NS32SFP+/2QSFP+	Network Switch 32 x SFP/2x QSFP+
NS48SFP+/4QSFP+	Network Switch 48x SFP+ 10G / 4x QSFP

Arqa User Guide

INDEX

4K	17	Fiber Switches	36	Returns Policy	32
A		Fitting the Correct P 3 2 SU Blade	15	RJ45 Socket LEDs	7
Arqa Network Manager	24	H		RS232 Baud Rate	21-22
Arqa RX1	7	Hide Status Screen	24	RS232 Connector Pinning	22
Arqa TX1	6	I		RX1 Settings	21
Attaching the Arqa TX1 Units to the RMK	15	IGMP Snooping	11-13	S	
Audio Input Gain	21	L		Schema EIA/TIA-568 B	34
Available Devices	18	LED Warnings	26-27	Searchbox Function	24
C		M		Selecting a Keyboard Layout	23
CATx Switches	34	Main Menu shortcuts	16	Setting up an IP Matrix Switching System	8
Changing the Keyboard Fallback Mode	22	Managing Favourite Devices	19	Show the Last Received Image	23
Changing the Settings of your Arqa Units	19	Manufacturer Warranty	32	Status LED	8
Class A Declaration of Conformity	30	Mounting Pads and Feet	14	Status Overview	17
Compliances	30	MTBF	31	Storage Temperature	31
D		Multi-Mode	34	T	
Defining DDC Data	17	N		TX1 Settings	19
Device List	24	No power (No LED)	26	U	
Dimensions	31	No video displayed	28	USB not working	28
Disposal	30	O		Using the On Screen Display	16
E		On Screen Display (OSD) Menu	16	Using the Power Save Mode	23
Editing Keyboard Shortcuts	24	Operating Temperature	31	V	
Enabling a direct connection	25	Optional Rack Mounting Kit	15	VGA Parameters	20
F		P		Video error	28
FCC Rules	30	Point-to-Point Connection	9	W	
Fiber Single-mode	35	Power Requirements	31	Weight	31
		Product End of Life	29		
		R			
		Relative Humidity	31		

Datapath UK and

Corporate Headquarters

Bemrose House, Bemrose Park,
Wayzgoose Drive, Derby,
DE21 6XQ, United Kingdom

☎ +44 (0) 1332 294 441
✉ sales-uk@datapath.co.uk

Datapath North America

2490 General Armistead
Avenue, Suite 102,
Norristown, PA 19403,

🇺🇸 +1 484 679 1553
✉ sales-us@datapath.co.uk

Datapath France

☎ +33 (1)3013 8934
✉ sales-fr@datapath.co.uk

Datapath Germany

☎ +49 1529 009 0026
✉ sales-de@datapath.co.uk

Datapath China

☎ +86 187 2111 9063
✉ sales-cn@datapath.co.uk

Datapath Japan

☎ +81 (0)80 3475 7420
✉ sales-jp@datapath.co.uk

www.datapath.co.uk

