

VIDEOLIFT

BRACKET FOR PROJECTORS, WITH PANTOGRAPH OPENING SYSTEM

VIDEOLIFT bracket is a motorized bracket suitable to anchor any type of video-projector to the ceiling. It can be completely hidden into the false ceiling as the panel, removed for installation, can be fixed to the bottom. Its anchoring system allows an optimal adjustment, also in the presence of some level flaws. The 3-positions switch allows to rise it, lower it and block it. The anchoring plate is completely perforated to facilitate the installation of various types of equipment. It is possible to adjust the limit switch both when rising and lowering.

Construction	Sturdy structure thanks aluminium and steel profiles which confer both lightness and sturdiness. The structure is partially painted in metallic grey and partially galvanized.
	Pantograph opening/closing system in galvanized steel.
	Support case totally perforated to facilitate anchoring and make the bracket compatible with the majority of projectors on the market.
Motor	Mono-phase electrical motor, absolutely reliable, class II, double insulation with self-resetting thermal protection which stops the motor in case the regular operating temperature is exceeded. The motor is IMQ and CE certified, with 5 years warranty from the date of purchase.
	Standard up/down electrical bracket's inverter.
	Lowering and raising limit switch factory adjusted, possibility of further different adjustments if needed. Possibility to stop the bracket at intermediate heights, by acting on the electrical inverter.
	Power supply: 230V / 50 Hz. Maximum consumption: 65W. Maximum load capacity: 15 Kg
Certifications	CE
Warranty	36 months at the conditions indicated in the user and maintenance manual.
Accessory (not included)	Home remote control, in-teo radio control, inverter, counter-ceiling finishing kit.

VIDEOLIFT bracket for projectors, with pantograph opening system

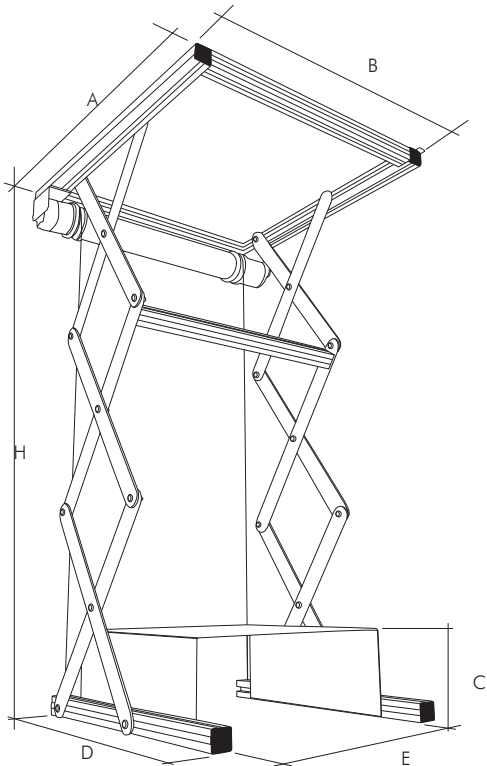

VIDEOLIFT 604394



VIDEOLIFT in the closed position

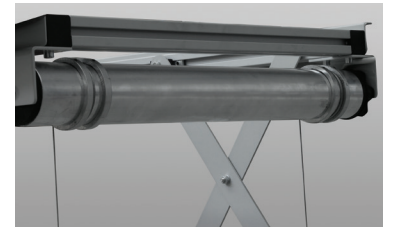

Close up of the lifting cable winding system

CODE	MODEL NAME	RUN	TOTAL SIZE CLOSED (AxBxC)	TOTAL SIZE OPENED (AxBxH)	PROJECTOR CASE (DxExC)	PACKING	NET WEIGHT	GROSS WEIGHT
604394	VIDEOLIFT 90	MAX 90	55 x 53 x 13,5	55 x 53 x 90	32,5 x 34,5 x 13,5	60 x 60 x 28	13	15,3
604395	VIDEOLIFT 200	MAX 200	55 x 53 x 28	55 x 53 x 230	32,5 x 34,5 x 13,5	60 x 61 x 28	17,2	20
604396	VIDEOLIFT HT	MAX 90	84 x 84 x 13,5	55 x 53 x 105	62 x 64 x 13,5	90 x 88 x 20	17,7	19
ACCESSORIES AND SPARE PARTS								
090015	HOME REMOTE RADIO CONTROL (receiver + transmitter) range up to 60m						-	0,20
090000	INTEO RADIO CONTROL (receiver + transmitter) range up to 200 m						-	0,20
090006	INVERTER at fixed positions with stop button, switch to be mounted on the wall						-	0,10
604398	COUNTER-CEILING FINISHING KIT FOR V-LIFT							
604399	COUNTER-CEILING FINISHING KIT FOR V-LIFT HT							
Size in cm, weights expressed in kilograms, diagonal expressed in inches (")								