

MOVMIPTMOTSP

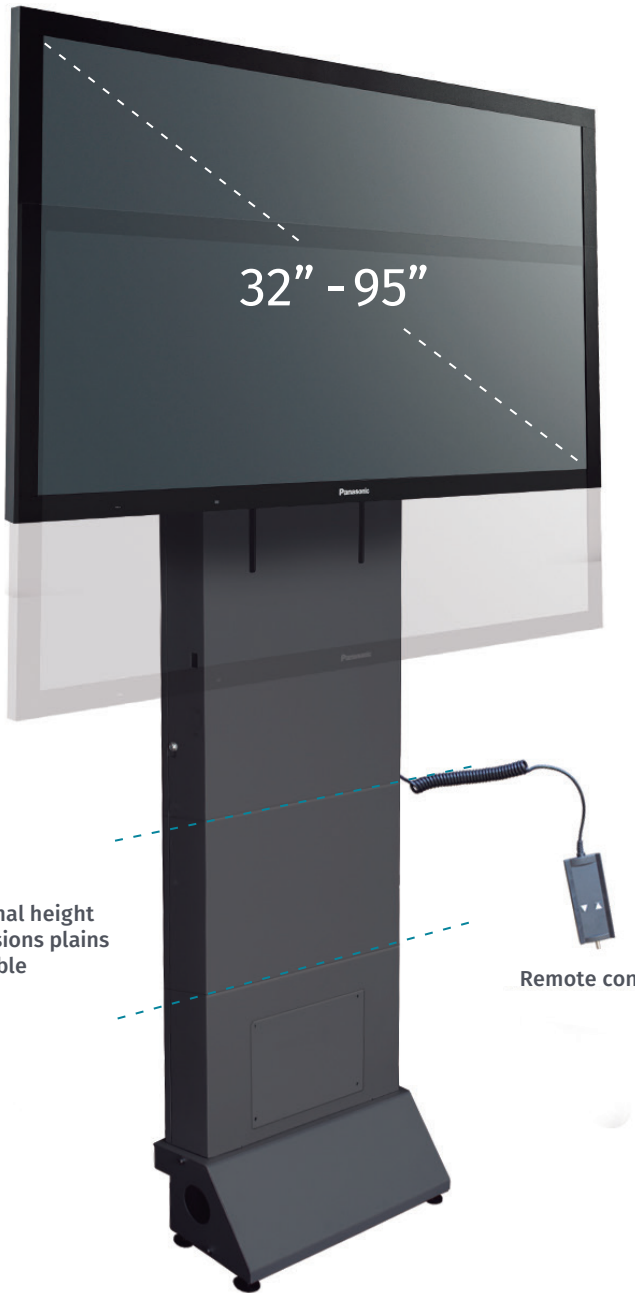

32" - 95"

45 cm height adjustment

Optional height extensions plans available

Remote control

Motorized wall mount, compatible with any kind of wall

SPECIFICATIONS

Ideally designed for touch LCD/ Plasma displays (education & corporate fields)

Accommodates displays from 32 to 95 inches

Electronic height adjustment

Max. movement: 450 mm

Remote control with built in security switch for avoiding accidents

Display lock

Simple installation

Max. display weight: 160 kg

Compatible with any kind of wall

Specially designed for achieving free distance between the wall and the back of the mount so that installation is compatible with any kind of existing baseboard or obstacle on the wall

Four legs with height adjustment for the use on any kind of floor surface

CE & UL certified

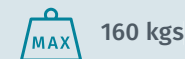
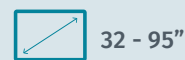

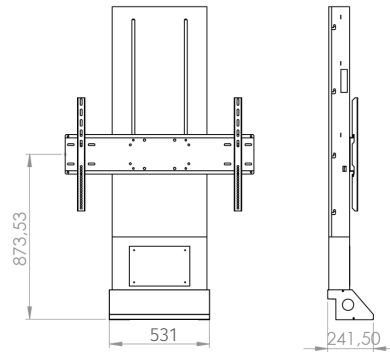
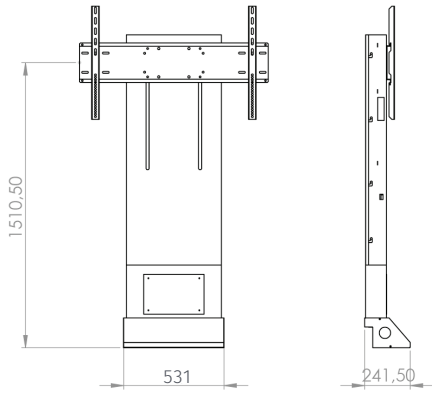
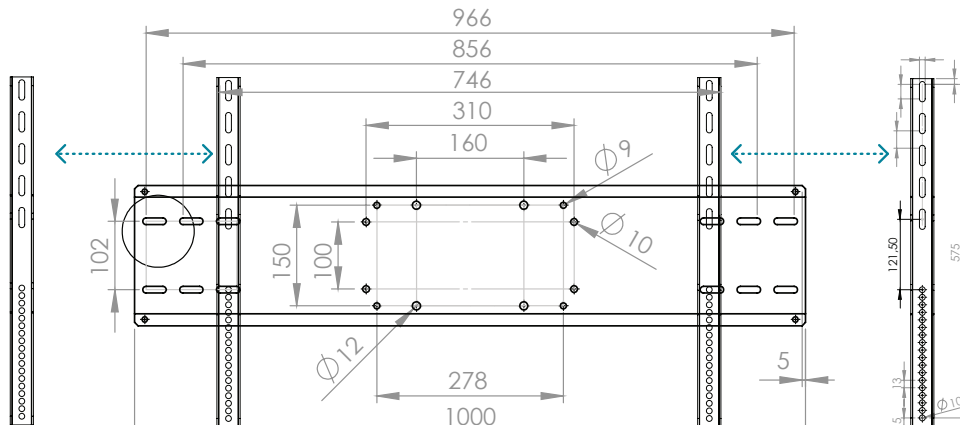

Maximum height

Minimum height

PRODUCT CONFIGURATIONS

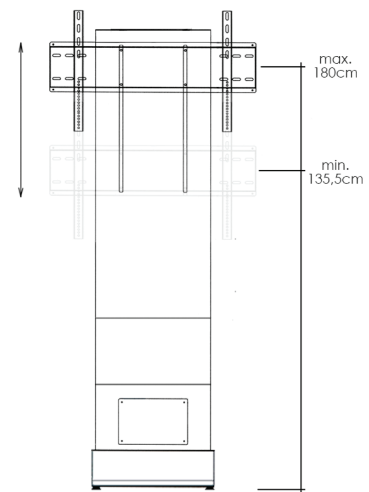
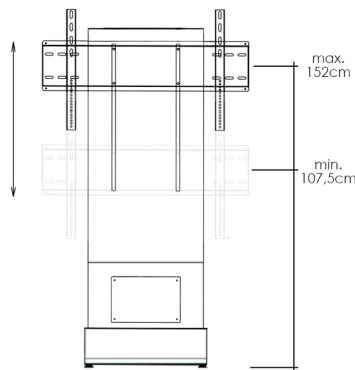
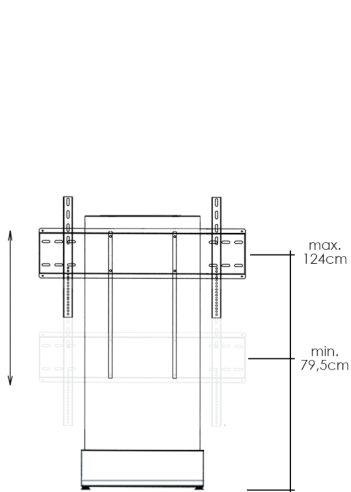

MIP MOT SUPER "ZERO"

With no extension plains

MIP MOT SUPER

With 1 extension plains (included)

**MIP MOT SUPER
+ MI EXTENSION PLAIN**