

SMS PRESENCE SHORT THROW MOBILE MOTORIZED

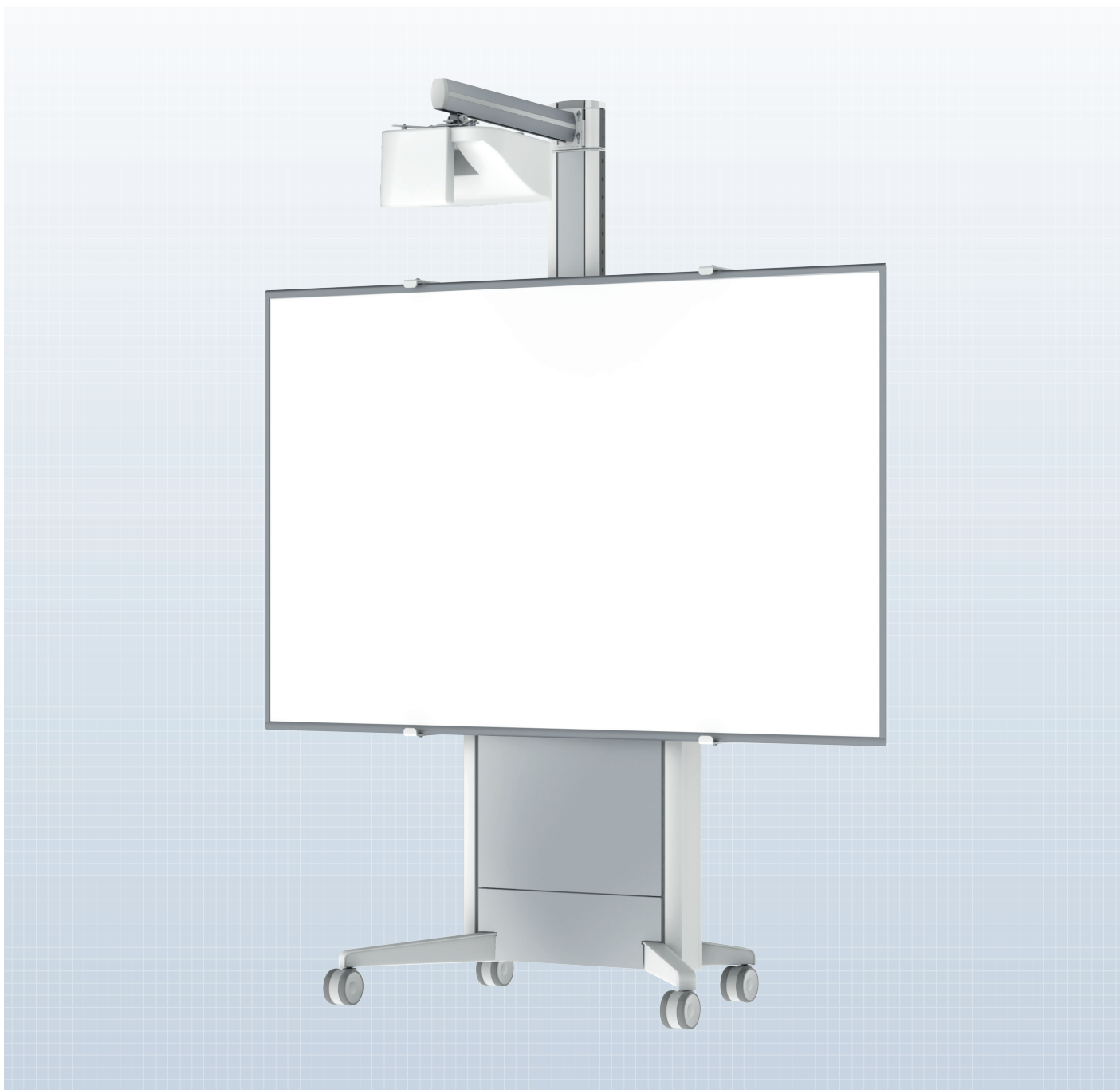

Several levels of mobile interactivity.

An ergonomic and flexible stand that is easy to move and easy to install. The unique design completely hides all cables and peripherals inside the stand. This means that it is attractive and elegant on all sides, and can be placed in the centre of the room. This solution, with its stable design, is perfect for large interactive boards. It is also possible to tailor its function to suit your use. The motorized height adjustment is soft and quiet, readily available from a button under the interactive board. The accurate factory assembly means that installation is easy and quick, while the hidden cable chain inside the stand ensures that the cables run freely with no risk of fastening. The mounting for the interactive board is universal. Finish: Aluminium/white.

QUESTIONS AND ANSWERS

How do I gain access to the cables and equipment inside the stand?

- Removable magnetic covers on both the front and the back of the stand make it easy to gain access to cables and other equipment.

Is it difficult to move the stand when an interactive board is mounted?

- No, it's very easy. Lower the interactive board using the motor before moving the stand, and remember to unplug it. The projector pillar can be easily turned to the side, if necessary, to pass through doors.

INFO

- Finish: Aluminium/white
- Tilt with SMS projector slide: $\pm 15^\circ$
- Travel: 500 mm
- Guarantee: 2 years
- Maximum projector weight: 8 kg
- Maximum total weight: 50 kg
- Maximum board height: 1,600 mm, minus the vertical projection distance
- Maximum board depth: 90 mm
- The maximum weight specifies the load capacity for the motor and stand. User experience may differ, depending on the choice of projector and interactive board. SMS is not responsible for such variation.
- Adjustments: Motorized raising and lowering
- A handle is included in the delivery.

ART. NO.
PR031050-P0

DESCRIPTION
SMS Presence Short Throw Mobile Motorized EU

Choose one of the following:

A: Choose the SMS projector pillar with the SMS Short Throw Unislide

B: If the projector is sold with an accompanying projector arm, it is possible to choose an adapter instead. More information is available at: www.smartmediasolutions.se.

A Projector pillar:

FS000680AW-P2 SMS Proj Short Throw 680 mm Alu/White

FS001202AW-P2 SMS Proj Short Throw 1,200 mm Alu/White

FS001600AW-P2 SMS Proj Short Throw 1,450 mm Alu/White

A Projector slide:

AE022021 SMS Projector Short Throw Unislide

B Adapters for projectors with an accompanying projector arm:

More information is available at: www.smartmediasolutions.se.

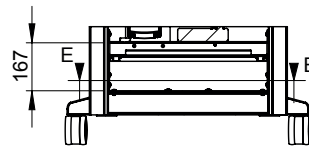
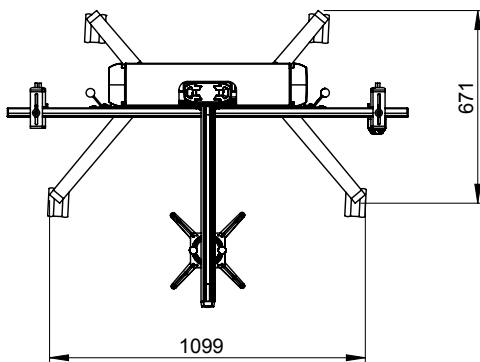
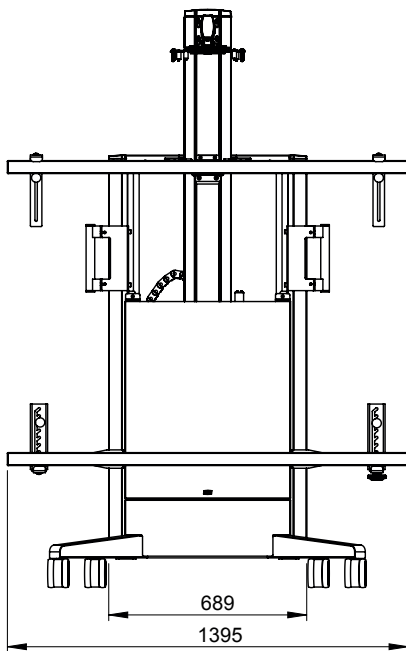

SECTION D-D
SCALE 1 : 20

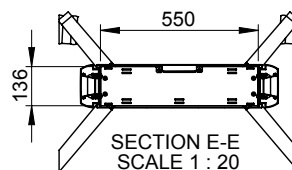

SECTION E-E
SCALE 1 : 20

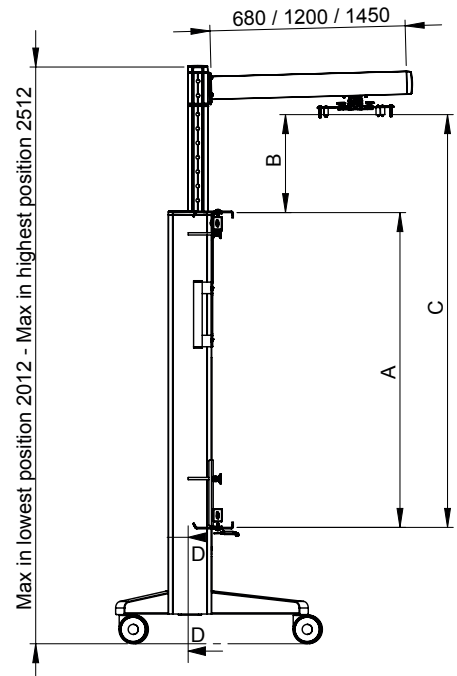

A = Board Height
B = Vertical projection distance
C = A + B

Max C = 1600 mm

Max board Width: -
Max board depth: 90 mm
Max board weight: 45 kg